

17596-550

Fig. 1 DIALUX-POL

- 1 Monocular tube
- 2 Iris diaphragm
- 3 Bertrand lens centring screws
- 4 Bertrand lens
- 5 Analyser rotation
- 6 Lever for the analyser
- 7 Knurled screw for rotating the analyser

- 8 Screw for arresting the analyser rotation
- 9 Revolving nosepiece with objectives
- 10 Object stage
- 11 Stage insert
- 12 Clamping screw and verniers for the rotating object stage

- 13 45°-interval click-stop
- 14 Aperture diaphragm lever
- 15 Polarizing condenser
- 16 Microscope stand
- 17 Field diaphragm
- 18 Combined fine and coarse adjustment
- 19 Microscope illuminator

3 Technical description

31 Microscope

The stand is equipped with a single-knob control on both sides (Fig. 1.18) for coarse and fine adjustment, which actuates the object stage (Fig. 1.10). One drum division corresponds to 0.002mm in the fine adjustment range. The total travel of the stage movement is 60mm in the DIALUX-POL. In the DIALUX-POL SB version the total stage movement is increased to about 80mm by the additional adjustment of the object stage.

The foot of the stand houses the field diaphragm (Fig. 1.17) and microscope illuminator (Fig. 1.19) with a 6v 15W low-voltage lamp, which is connected to the mains via a regulating transformer.

The polarizing condenser 702f (1.15) is mounted in a dovetail changer below the object stage. In addition to the swing-out and rotating filter polarizer (8.30) it has an aperture diaphragm (8.14) and a swing-out condenser top (8.27).

When the top is swung in, the condenser has an aperture of 0.90. If maximum resolving power is essential in the condenser, the condenser top can be replaced by one of aperture 1.33.

Brightfield-, darkground-, and phase contrast condensers can be inserted in the dovetail changer instead of the polarizing condenser.

The rotating object stage (1.10), which runs on ball bearings, has a 360° graduation; this can be read to an accuracy of 0.1° by means of two verniers. A clamping screw (1.12) serves for adjusting the friction and for arresting the stage in any desired position.

Built-in 45°-interval click-stops (1.13) automatically arrest the stage from any

desired initial position. When a universal rotating stage is used the annular insert (1.11) is removed from the object stage.

Revolving nosepieces, objective centring clutch, or incident-light illuminators such as the pol-vertical illuminator, UL-TROPAK, and metallographic vertical illuminator are inserted in the horizontal slide guide of the top part of the stand. All objectives can be individually centred in the centre of the stage on the revolving nosepiece, centring clutch, and pol-vertical illuminator. Compensators can be inserted at an angle of 45° in the compensator slot. The analyser (1.6) can be swung in and out and rotated. The rotation (1.5) can be read to 0.2° off a scale. In the zero position the orientation of the vibration direction corresponds to the horizontal (east-west) thread. The following tubes can be inserted in the bayonet clamp:

- 1) Monocular pol-tube P 10 with inclined observation tube for the use of eyepieces of enlarged field of view and a built-in iris diaphragm for masking the surroundings of object detail during conoscopic investigations.
- 2) Binocular pol-tube S 20 with inclined observation tubes for eyepieces of standard diameter.
- 3) Straight phototube O 13 with iris diaphragm as under 1.
- 4) Pol-phototube FS 21 with inclined binocular observation tube for eyepieces of standard diameter, and straight tube part for eyepieces of enlarged field of view and support ring and index. Pinhole stop for masking the surroundings of object detail during conoscopic investigations.

32 Objectives, eyepieces

For investigations in polarized light objectives in strain-free mounts are used; they are mostly achromats or plan-achromats. Except the low-power objectives all objectives have spring-loaded front lens mounts in order to avoid damage of the specimen and the valuable optical systems as far as possible. All the data important to the user of the microscope are engraved on the objective mounts, for instance

170/0.17

50/0.85 P

Where

170 = the mechanical tube length for which the Leitz transmitted-light objectives are computed,

0.17 = the ideal coverglass thickness which should be adhered to as closely as possible,

50 = the reproduction scale or objective magnification,

0.85 = the numerical aperture, which determines the resolving power of the objective,

P = strainfree mount for polarized-light microscopy.

Oil immersion objectives are distinguished by the engraved word Oel and a black ring. For the conoscopic observation of interference figures the use of the 50/0.85 objective P is recommended because of its relatively large aperture. Obviously objectives of still higher magnification and larger aperture can be used if necessary.

Objectives for incident-light investigations with the pol-vertical illuminator have been computed for a mechanical tube length of 215mm. The engraved values have the same significance as already described.

Eyepieces

Eyepieces of 30mm diameter are used for monocular tubes.

Binocular tubes accept eyepieces of standard diameter of 23.2mm.

All eyepieces including crosslines are inserted in the tube at a fixed orientation (see section 4, p. 9). The horizontal line corresponds to the vibration direction of the analyser, and the vertical line to that of the polarizer.

If the crosslines eyepiece is inserted in the tube after rotation through 45° , the crosslines correspond to the vibration directions of birefringent objects in the diagonal position and those of compensators inserted into the beam respectively. Eyepieces with crosslines or graticules for measuring purposes have focusing eyelenses. The magnification of the eyepieces is engraved on the mount.

The total magnification of the microscope image is calculated as follows, $M_{\text{Objective}} \times M_{\text{Eyepieces}} \times M_{\text{tube factor}}$ (see also table on p. 16).

In monocular tubes a tube factor 1x, in binocular tubes a tube factor 1.25x must be introduced.

33 Pol-vertical illuminator

For investigations in polarized incident light the DIALUX-POL is equipped with the pol-vertical illuminator (Fig. 10). In addition to a plane glass the vertical illuminator includes the compensating prism (trapezoidal prism according to Berek), which provides a homogeneous, linearly-polarized field.

The plane glass is used when high resolution is necessary (high magnifications) and the quality of polarization of the light is not very critical, for instance in photomicrography.

The prism polarizer (10.37) can be rotated and, by means of the graduation, accurately orientated. The field diaphragm (10.36), aperture diaphragm (10.40) and a half stop (10.39) are housed in the illumination tube.

The attached, centring microscope illuminator with 6v 15W low-voltage lamp is, like the transmitted-light illuminator, connected to the mains through the regulating transformer.

34 Compensators

Two compensators of fixed path difference form part of the basic outfit: λ -plate and $\lambda/4$ -plate. The vibration direction γ is always engraved. The compensators are inserted in the compensator slot on the revolving nosepiece, in the objective centring clutch, or in the vertical illuminator.

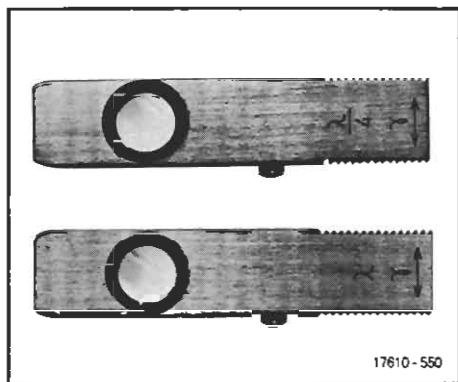

Fig. 2
 $\lambda/4$ -plate
 λ -plate (red first order)

Insert the bulb into the socket of the lamp mount, depress it and lock it by a right turn. Insert the microscope illuminator in the foot of the stand and connect it to the mains through the regulating transformer.

Ascertain that type of current and voltage are correct. If another light source is used such as the sodium lamp or gas discharge lamps in connection with the Lamp Housing 250, the lamp condenser must be removed from the foot of the stand, see Fig. 3.

Insert the condenser in the dovetail changer and raise it as far as possible. Swing the condenser top (8.27) into the beam.

Turn the polarizer (8.30) in and after releasing the clamping screw (8.31) zero it. Re-tighten clamping screw.

Release the clamping screw of the object stage. The 45°-interval click-stops must be disengaged.

Insert the objective holder into the dovetail guide of the top part of the microscope and clamp it in position. Insert the objective.



Fig. 3
Removing the lamp condenser from the
microscope stand

With the revolving nosepiece (1.9):
 Screw the objectives into the threads in the order of their magnifications. Lowest-power objective in thread No. 1, next-higher power in thread No. 2 etc. With the objective centring clutch (4.22):
 Screw the objectives into the centring changing rings (4.20) and insert them in the clutch holder from the left. Push the clutch (4.22) together and lock the objective in position by a left-hand turn. Release the clutch.
 When the lever (1.6) points to the rear against the stop the analyser will be in the beam. Drop the tube into the top part of the stand so that the two red index

marks are situated above each other. Now rotate the tube as far as it will go through about 45° to the right, thereby locking it in position.
 Insert the eyepiece or pair of eyepieces in the tube. The lateral lug of the cross-lines eyepiece should engage in the groove of the eyepiece tube so that the crosslines run horizontally and vertically. They thereby indicate the vibration direction of polarizer and analyser when both are crossed (zero position). Ensure that the Bertrand lens (1.4) is removed from the beam path and the iris diaphragm (1.2) in the monocular tube is completely open.

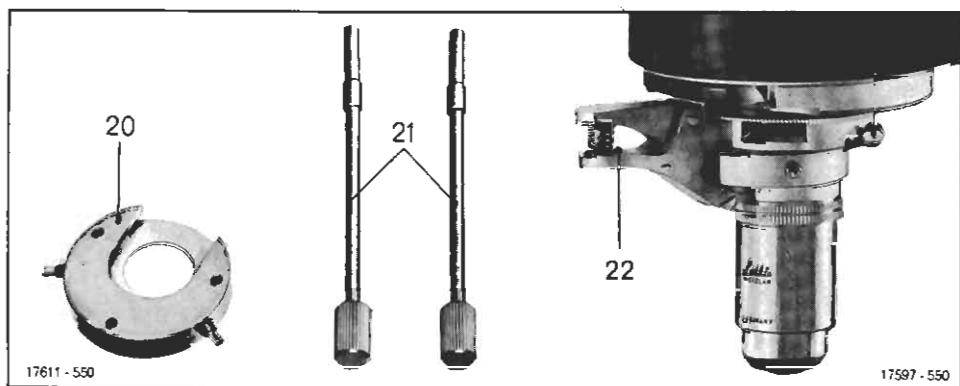

Fig. 4
 20 Objective centring ring
 21 Centring keys
 22 Objective centring clutch with objective in position

5 Operation of the microscope

51 Operation with transmitted light

Switch on the illuminator on the transformer. Open the field diaphragm (1.17) and place the centring disc (Fig. 6) on the dust glass.

When clamping screw (5.25) has been released the illuminator can be adjusted to the lamp condenser built into the foot of the stand. This adjusts the size of the illuminated field, which can be very well observed on the centring disc. Pull out the illuminator until the field illuminated on the centring disc is at its smallest.

After the knurled screw (5.26) has been released the lamp can be laterally adjusted. This makes it possible to form an image of the luminous patch exactly in the centre of the centring disc. Re-tighten the knurled screw (5.26) and remove the centring disc.

Turn out the analyser and place a specimen, such as a thin polished section, on the object stage. Turn in or insert 10/0.25 objective, and focus the specimen by means of the coarse and fine adjustment.

Now slowly push the lamp mount back into the foot of the stand, observing it in the eyepiece, until optimum illumination has been obtained. Re-tighten the clamping screw (5.25).

Push the centring keys (4.21) supplied onto the threaded pins of the objective. A smooth rotation of the object stage will reveal a point in the specimen around which all other points rotate. Centre this point, which represents the rotating axis of the stage, critically in the centre of the crosslines with the aid of the centring keys. Remove the cent-

ring keys. Centration is preserved also after a change of objectives. All the other objectives should be centred in the same way.

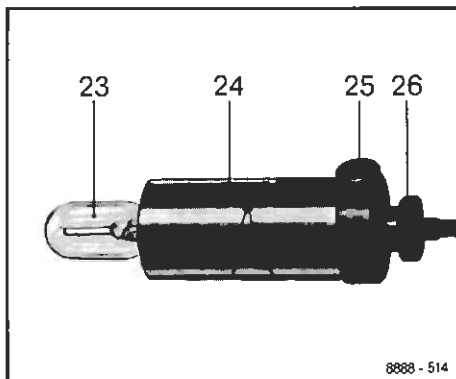

Fig. 5
Microscope illuminator
23 6v 15W bulb
24 Lamp mount
25 Clamping screw
26 Knurled screw for the lateral adjustment
of the lamp

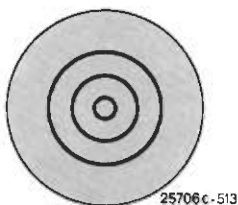

Fig. 6
Centring disc

511 Centring the condenser

Close the field diaphragm (1.17). Vertically adjust the condenser until a sharp image of the field diaphragm is formed simultaneously with that of the specimen. Move the field diaphragm into the centre of the field of view by means of the two centring screws (8.29). Open the diaphragm until it just disappears beyond the edge of the field of view.

This represents the optimum adjustment of the condenser, which should be checked after a change of the objective and the specimen.

The aperture diaphragm (8.14) determines resolution, contrast, and depth of field of the microscopic image. Ordinarily it is stopped down to about 2/3 of the objective aperture. This can be checked by observation of the rear focal plane of the objective after the Bertrand lens is turned in below the eyepiece. Since the objectives have different apertures, the aperture diaphragm must be readjusted each time the objective has been changed.

When objectives of apertures smaller than 0.25 are used the condenser top (8.27) must be turned out. Close the field diaphragm and lower the condenser below the stage until a sharp image of the field diaphragm is obtained. Now open the field diaphragm again and turn the analyser in.

The microscope is now ready for observation in the orthoscopic beam path.

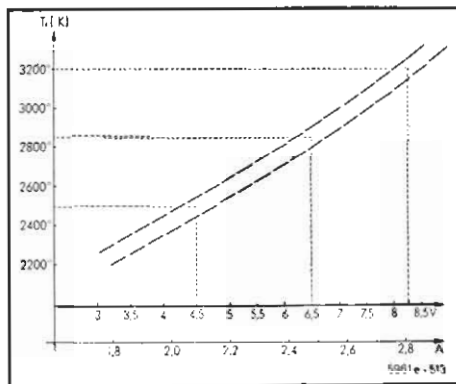

Fig. 7
The colour temperature as function of the current load on the low-voltage lamp

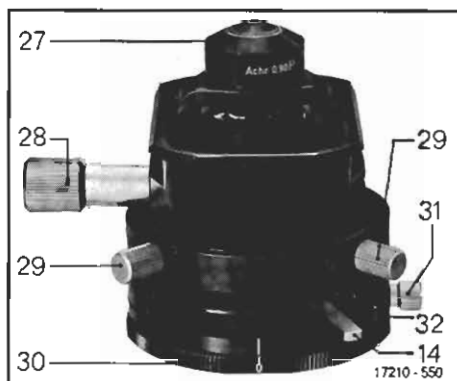











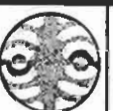



Fig. 8
Polarizing condenser
14 Aperture diaphragm
27 Condenser top (swing-out lens)
28 Knurled knob for operating the swing-out lens
29 Centring screws
30 Polarizer
31 Clamping screw for polarizer
32 Sliding filter

512 Setting interference figures

Adjust the microscope as described under 5.1. Turn in and centre 50/0.85 objective. Move the specimen into the centre of the crosslines. Completely open the aperture diaphragm and field diaphragm. With lever (1/4) turn the Bertrand lens in and focus it. Centre the Bertrand lens in the field of view with the two centring screws (1.3). With small objects the disturbing surroundings can be eliminated if the iris diaphragm (1.2) is closed or if the pin-hole stop in the pol-phototube FS 21 is turned into the beam. For the conoscopic observation of very small specimens the use of objectives of high magnification, such as Oel 100/1.30, is recommended. The character of the birefringence is deter-

mined with the aid of the two compensators supplied by means of the table below.

	+		+		-	
						
						
<p>* Beim $1/4\lambda$-Glimmerplättchen treten an Stelle der schwarzen Bogen schwarze Punkte auf.</p>						

26 290 - 550

* with the $1/4 \lambda$ mica plate black dots replace the black arcs.

Fig. 9
Table for the determination of the character of birefringence

52 Operation with incident light with the pol-vertical illuminator

Insert and clamp the vertical illuminator instead of the objective holder for transmitted light in the dovetail guide.

Insert the lamp into the microscope illuminator, connect it to the mains through the regulating transformer, and switch it on.

It is best to set up the microscope so that the back of the stand points towards the user; the tube should be inserted accordingly. For the adjustment of the instrument it is advisable to turn out the analyser. After the clamping screw has been released, zero the polarizer (10.37). Re-tighten the clamping

screw. Turn in the deflecting prism by pushing the knurled knob (10.34) in. (pulled out = plane glass in the beam path). Place the specimen on a metal object slide in a piece of plasticine and press it into it by means of the hand-press Fig. 12, which must be briefly held in its lowest position. Screw the objective (e.g. 16/0.40) into the centring ring and insert it in the holder of the clutch. Place the specimen on the object stage and focus it critically. Centre the object as described under 5.1.

Close the field diaphragm (10.36) and focus it (10.35). Tilt the knurled knob (10.34) slightly in order to move the field diaphragm into the centre of the field of view; the deflecting prism has now been

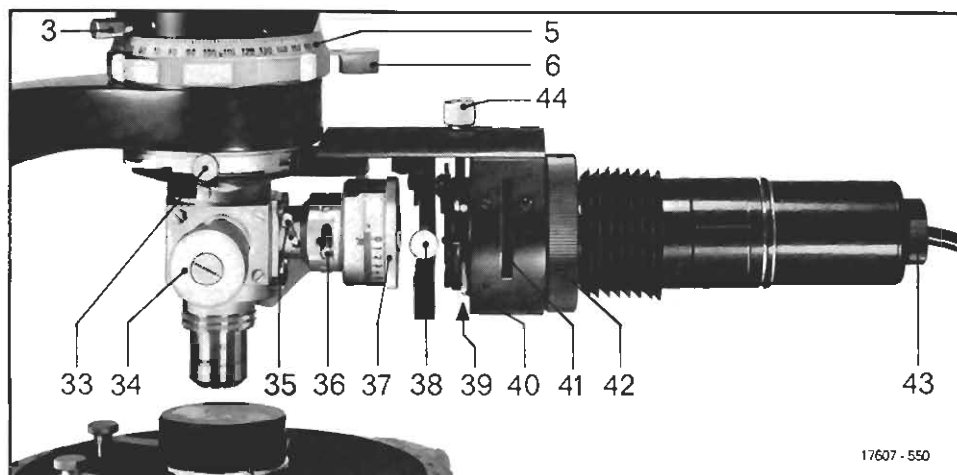

Fig. 10

Pol-vertical illuminator

- 33 Knurled screw for clamping the vertical illuminator or the revolving nosepiece
- 34 Knurled knob for pushing in the prism or plane glass
- 35 Field diaphragm focusing lever
- 36 Field diaphragm
- 37 Polarizer

- 38 Slide with central stops
- 39 Half stop (not visible)
- 40 Aperture diaphragm
- 41 Filter slot
- 42 Knurled ring for releasing the microscope illuminator
- 43 Knurled screw for the lateral adjustment of the lamp
- 44 Knurled screw for the vertical adjustment of the aperture diaphragm (oblique illumination)

correctly adjusted. Now open the diaphragm so that it just disappears beyond the edge of the field of view.

For centring the lamp turn the Bertrand lens (1.4) in. Release the knurled screw (10.43) and centre the lamp in the exit pupil. By adjustment of the lamp mount even illumination is obtained. Close the aperture diaphragm (10.40) by about 1/3. Correct the vertical adjustment of the aperture diaphragm with screw (10.44) (see Fig. 11).

Turn out the Bertrand lens. Turn in and zero the analyser. Check the dark position of the crossed polarizers, preferably on a highly reflecting isotropic object and if necessary readjust the polarizer (10.37). Any disturbing reflections in the lower part of the field of view can be eliminated with the aid of the half stop (10.39).

If light sources independent of the microscope are to be used, the low-voltage illuminator is unscrewed with the knurled mount (10.42) and replaced by the lamp condenser (13.46), which is screwed into the thread.

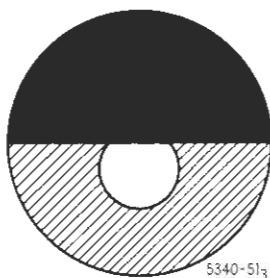

Fig. 11
Correct position of the aperture diaphragm and useful aperture limitation (image with the Bertrand lens turned in or the eyepiece removed and Berek prism in the beam)

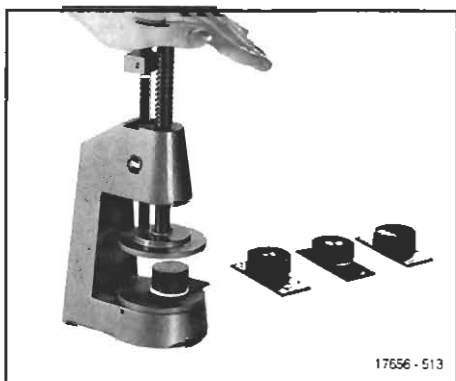

Fig. 12
Handpress for aligning the specimens

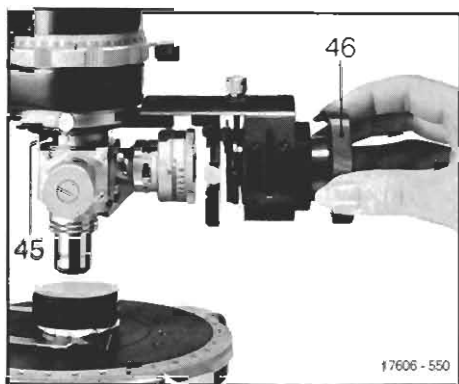

Fig. 13
Screwing in the lamp condenser (46) for separate light sources
45 Tube slot for compensators
46 Lamp condenser

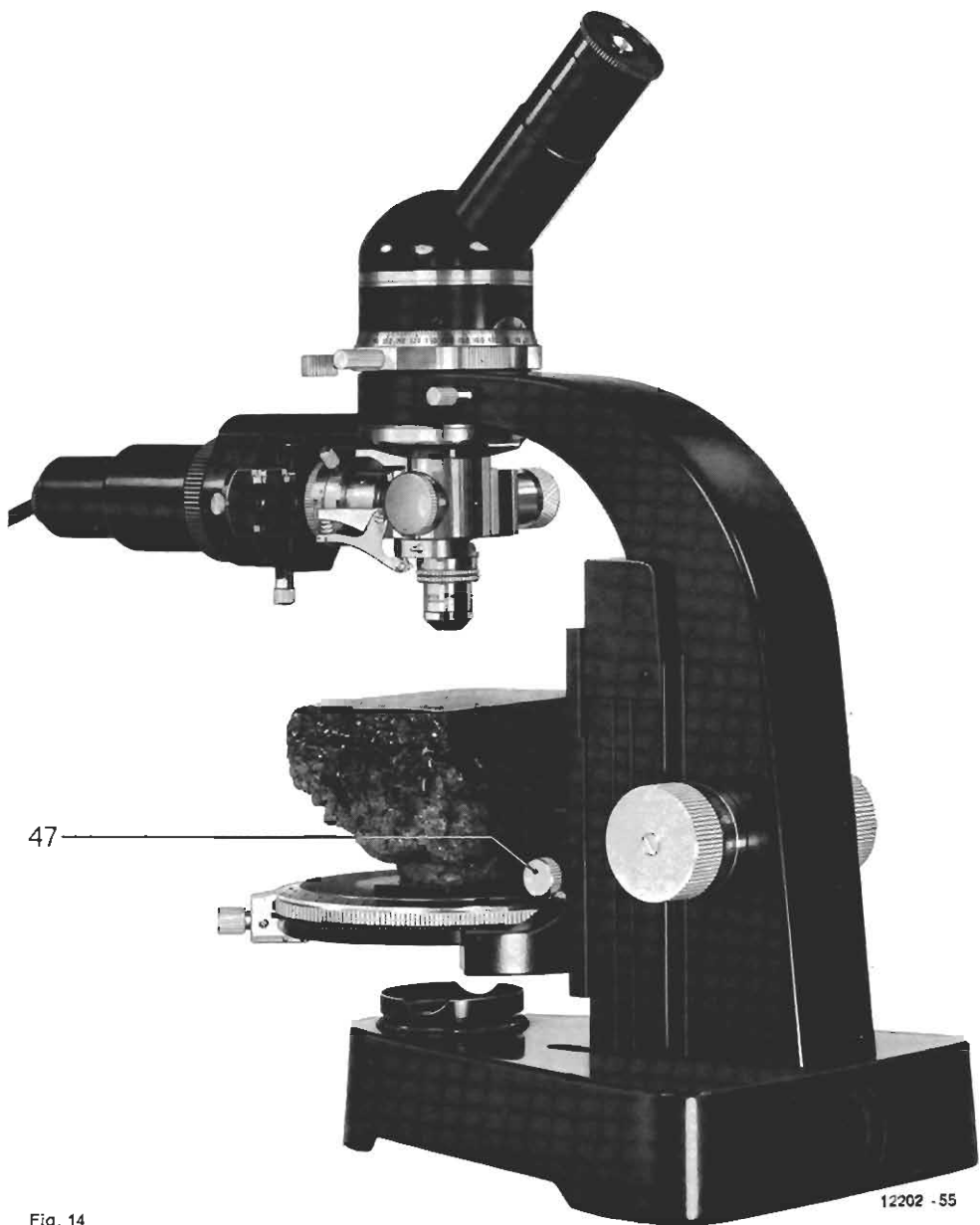

Fig. 14
DIALUX-POL SB

In the DIALUX-POL SB vertical adjustment of the object stage is possible in addition to the usual coarse- and fine adjustment after release of the clamping screw (14.47).

The microscope is now ready for investigations in polarized incident light. If any other accessories are used the relevant operating instructions should be consulted.

Magnification table

for LEITZ-microscopes

Tube factors $0.8x \leftarrow 1x \rightarrow 1.25x$

Objective magnification	Total magnification with Huygens or PERIPLAN [®] eyepieces						
	6.3x	8x	10x	12.5x	16x	20x	25x
1	6.3	8	10	12.5	16	20	25
2.5	16	20	25	32	40	50	63
3.2	20	25	32	40	50	63	80
3.5	22	28	35	45	55	70	90
4	25	32	40	50	63	80	100
5	32	40	50	63	80	100	125
5.6	35	45	56	70	90	110	140
6.3	40	50	63	80	100	125	160
8	50	63	80	100	125	160	200
10	63	80	100	125	160	200	250
11	70	90	110	140	175	220	275
12.5	80	100	125	160	200	250	320
16	100	125	160	200	250	320	400
20	125	160	200	250	320	400	500
22	140	175	220	275	350	440	550
25	160	200	250	320	400	500	630
32	200	250	320	400	500	630	800
40	250	320	400	500	630	800	1000
50	320	400	500	630	800	1000	1250
54	340	430	540	675	860	1080	1350
55	345	440	550	690	880	1100	1375
60	380	480	600	750	960	1200	1500
63	400	500	630	800	1000	1250	1600
70	450	550	700	875	1125	1400	1750
75	475	600	750	950	1200	1500	1875
80	500	630	800	1000	1250	1600	2000
90	565	720	900	1125	1450	1800	2250
95	600	760	950	1200	1525	1900	2375
100	630	800	1000	1250	1600	2000	2500
105	650	850	1050	1325	1675	2100	2625
160	1000	1250	1800	2000	2500	3200	4000

The total magnifications refer to the tube factor 1x. The magnifications with the tube factors 0.8x and 1.25x respectively can be found in the table by moving from the value found for "tube factor 1x" into the adjacent column to the left = 0.8x and to the right = 1.25x.

All magnification values printed in bold type correspond to the standard magnifications obtained by multiplication of an objective - by an eyepiece standard magnification. The other magnification values have been rounded up where necessary.



Design subject to alteration without notice.

ERNST LEITZ D 6330 WETZLAR GMBH GERMANY

Subsidiary:

Ernst Leitz (Canada) Ltd., Midland, Ontario

List **550-12a/Engl.** Printed in Germany IX/70/DX/L