

scanned by J. G. McHone 16 Jan 2010
for personal use only, not for sale

INSTRUCTION MANUAL

FOR USE OF

OLYMPUS FILAR MICROMETER

EYEPIECE OSM

MEASUREMENT WITH AN OLYMPUS FILAR MICROMETER EYEPIECE OSM

(Catalog #2-C790)
#2-C791)

1. In instances where measurements with an eyepiece micrometer disk are not accurate enough for the user's purpose, a filar micrometer eyepiece (OSM) should be employed. The filar micrometer eyepiece must be calibrated for each objective with which it might be used. The calibration of the arbitrary field of view scale divisions and the external filar drum divisions is done against the known values of a stage micrometer scale.
2. The stage micrometer is a 1" X 3" slide with an etched scale, usually of 100 equal small divisions; the entire scale is usually 1 millimeter (1000 microns) long. Every fifth and tenth division is usually a somewhat longer vertical line to enable the user to count the stage micrometer readings more readily. Every small division is equal to 10 microns; five divisions equal 50 microns; ten divisions equal 100 microns. The stage scale is the known scale of lengths. (Some stage micrometers are calibrated in fractions of an inch rather than metrically). Fig. 1A, Fig. 1B

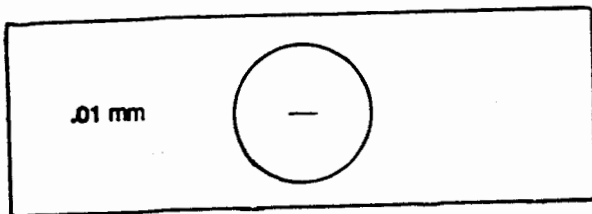

FIG. 1A STAGE MICROMETER

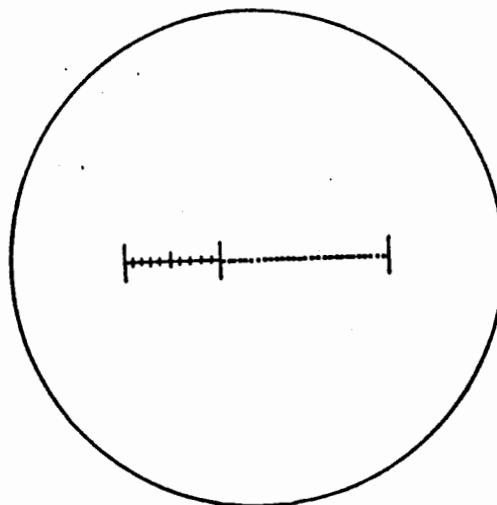
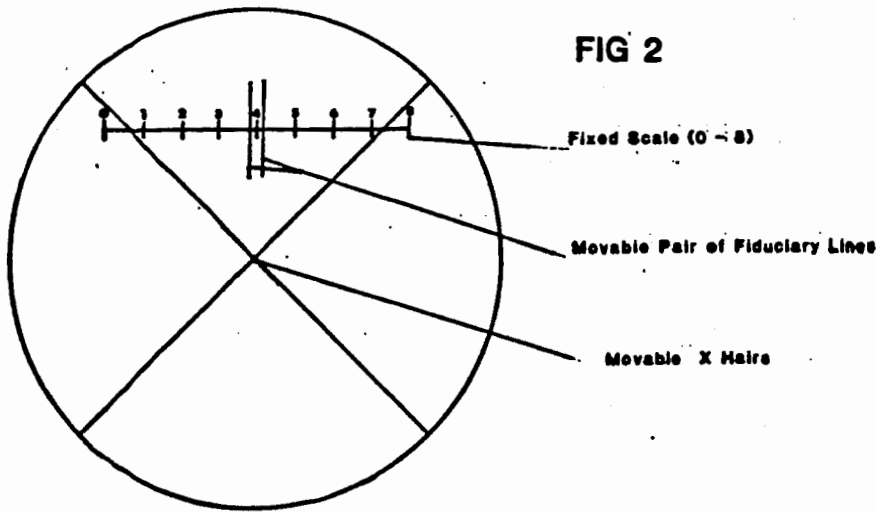

FIG. 1B

Each Small Division = 10 μ
Every Five Divisions = 50 μ
Every Ten Divisions = 100 μ
Entire Scale = 1000 μ

3. The filar micrometer eyepiece has an adjustable eye lens with a fixed scale, 0 to 8 in the field of view. Also in view, there is a pair of vertical (fiduciary) lines which move along the fixed scale as the external drum is rotated by the user. Below the fiduciary line pair, there are intersecting X hairs which travel across the field of view simultaneously as the fiduciary line pair is moved. The intersection of the X hairs makes possible accurate readings of the position of the moving lines above them as the X hairs travel across the object being measured.
 Fig. 2



4. At right angles to the filar eyepiece and attached outside the eyepiece, there is a rotatable drum, divided into 100 equal divisions; each tenth division is numbered; each fifth division line is slightly longer to make readings easier. As the external drum is turned by the operator, the fiduciary lines in the field of view are actuated to move across the fixed scale in the field of view; simultaneously the intersecting X hairs travel across the field of view. When the fiduciary lines are exactly on 4 of the fixed scale and the drum is at 0, the intersection of the X hairs is exactly in the center of the field of view. Fig.3

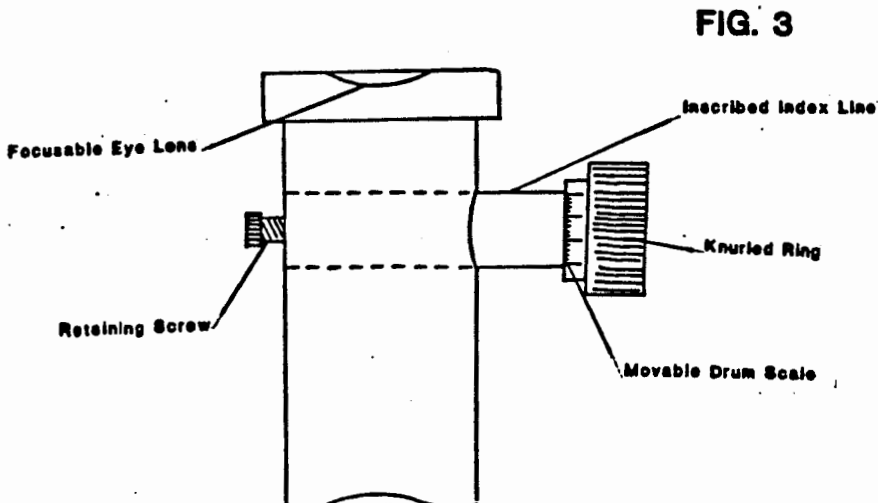

Each complete rotation of 100 small divisions of the external drum moves the X hairs and the fiduciary lines the equivalent of 1 whole space on the field of view fixed scale. The drum divisions are read against an index line engraved on the outside of the filar eyepiece.

For example, 2 full turns of the drum and a partial turn of 37 small divisions equals 237 small divisions of the drum.

For ease of calibration, it is convenient to start a measurement with the fiduciary lines straddling 4 on the fixed scale in the field of view and the external drum reading 0.

5. The task is to calibrate the arbitrary value of each small division of the external drum (100 of these is equal to one whole space on the fixed scale in the field of view) against the known values of each small division of the stage micrometer scale (10 microns each) FOR EACH OBJECTIVE. The calibration for each objective is recorded for future use. Thus, when measuring an unknown length of a specimen, the filar micrometer can be used without need for a known stage scale.

Procedure Using a 10X Objective as an Example

- A. Place the stage micrometer on the microscope stage and focus as usual until the lines appear sharp. Using the mechanical stage, center the stage scale in the field of view so that the vertical lines are oriented North-South and the stage scale centered in the field of view from "9 o'clock to 3 o'clock" positions.
- B. Remove the visual eyepiece from the microscope body tube (for a binocular, use the eye tube which is not adjustable).
- C. Hold the filar eyepiece toward a bright light. Using the adjustable eye lens of the eyepiece, focus the field of view fixed scale (0-8) and X hairs so that they appear sharp.

- D. Insert the filar eyepiece into the microscope tube. Without changing the filar eyepiece focus, orient the filar eyepiece so that the fixed eyepiece scale in the field of view (0 to 8) is East-West; 0 on the left, 8 on the right. Without changing the adjustment of the eyelens of the filar micrometer, tighten the retaining screw of the filar eyepiece so that it is fixed to the microscope body tube. The scale in the field of view will be seen approximately extending from "10 o'clock to 2 o'clock" position. If the drum is turned so that the fiduciary pair of lines is at 4 in the field of view and the external drum reading is at 0, the X hairs will be seen in the center of the field of view.
- E. If the microscope being employed is the Vanox or the BH-2, an adapter (Cat. #B-0670) must be used. The filar eyepiece has to be fixed by retaining screw to the adapter. Then proceed as in C and D above, this time using the adapter retaining screw to be tightened to the microscope tube.
- F. Using the mechanical stage, move the stage micrometer scale so that a longer vertical line (a tenth division) is oriented North-South and is exactly intersected by the traveling X hair of the filar; the moveable fiduciary lines are also oriented North-South.
- G. Starting with the external drum at 0 and the X hair intersecting the longer vertical line of the stage scale, rotate the external drum toward the user (going from 0 upwards). While looking at the X hairs, move the X hairs so that the X hairs and fiduciary lines travel a distance of 10 small spaces on the stage scale. Record the "starting" number on the fixed scale and the "finishing" number on the fixed scale, e.g., 4 to 5; also record the number on the external drum.

Fig. G1, Fig. G2

e.g. 1 whole space on the fixed scale = 100 small drum
in the field of view = divisions
39 on drum reading = 39 small drum divisions
Total -- 139 small drum divisions

$$K = \frac{\# \text{ Small spaces on stage scale}}{\# \text{ Total drum divisions}}$$

$$K = \frac{10 \text{ Small spaces on stage scale}}{139 \text{ Total drum divisions}} = \frac{10 \times 10\mu}{139}$$

$$K = \frac{100 \text{ Microns}}{139} = 0.719\mu = \text{Value of each small drum division for this objective}$$

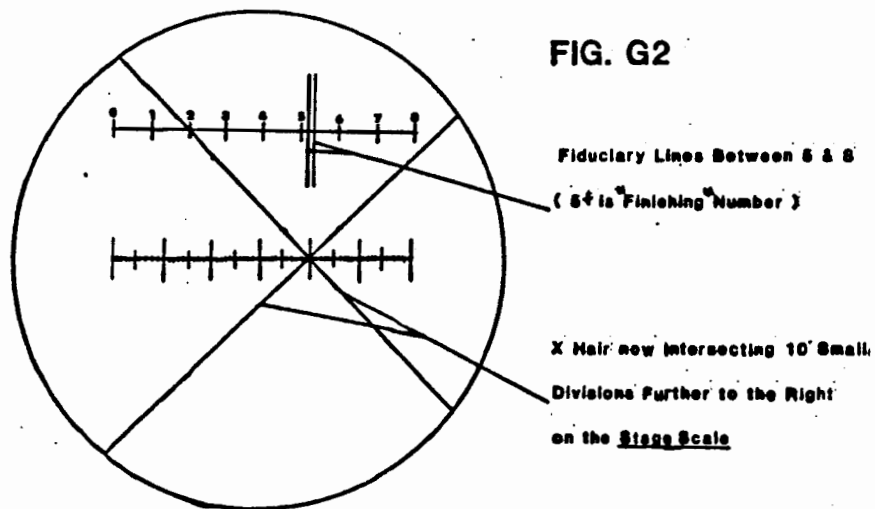
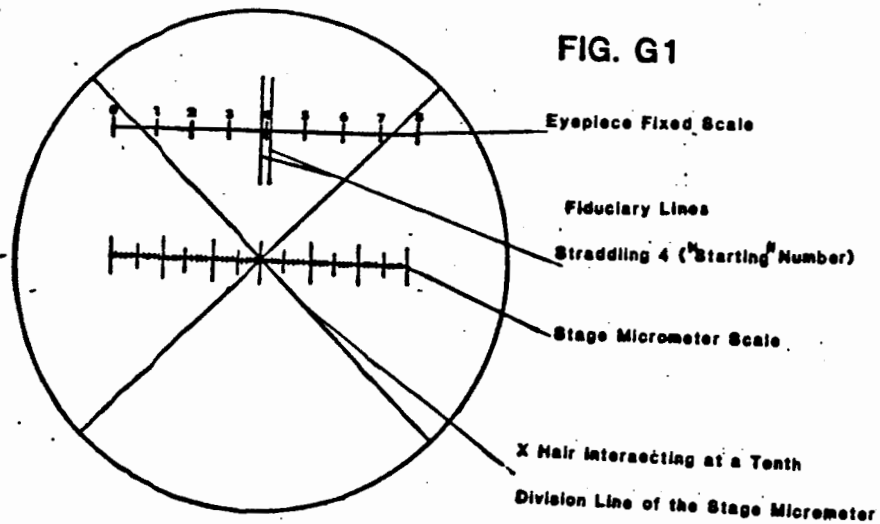

For this objective,

One small drum division = 0.719 microns;

One whole space in the fixed eyepiece scale = 71.9 microns

If the user measures a specimen and finds that it takes two whole fixed spaces in the field of view and 27 drum divisions of the filar to traverse the specimen, then the specimen length would be 227 (200+27) X 0.719 μ = 163.2 microns for this objective and specimen.

H. For the 40X Objective, for example: Only a limited segment of the stage micrometer scale will usually be visible at this magnification. Proceed as follows for this objective:

1. Turn the external drum of the filar so that it is at 0.
2. Using the mechanical stage, align the stage scale so that the X hair intersection is superimposed on one of the longer vertical lines of the stage scale. Read the "starting" number on the eyepiece fixed scale. Rotate the filar drum until the X hairs travel 5 small spaces on the stage scale. Now read the "finishing" number on the eyepiece fixed scale. Add the number reading on the outside drum. This gives the total number of filar small divisions traveled.

