

# OLYMPUS®

---

## INSTRUCTIONS

# BX51/52-P, BX41-P

## POLARIZING MICROSCOPE

This instruction manual is for the Olympus Polarizing Microscope Model BX51/52-P, BX41-P. To obtain optimum performance and to familiarize yourself fully with the use of your microscope, we recommend that you read this manual together with the instruction manual for the BX51/BX52, BX41 microscope thoroughly before use. Retain this instruction manual in an easily accessible place near the work desk for future reference.

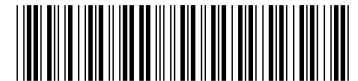

A X 7 3 4 4



Printed on 100% recycled paper with soy ink.

# CONTENTS

<b>IMPORTANT – Be sure to read this chapter for safe use of the equipment. –</b>	<b>1</b>
<b>1 NOMENCLATURE</b>	<b>2</b>
<b>2 ASSEMBLY</b>	<b>3-9</b>
2-1 Assembly Diagram .....	3
2-2 Detailed Assembly Procedure .....	4-9
<b>3 CONTROLS</b>	<b>10-11</b>
<b>4 USING THE CONTROLS</b>	<b>12-15</b>
4-1 Stage .....	12-14
4-2 Intermediate Polarizing Attachment .....	15
<b>5 POLARIZED LIGHT OBSERVATION</b>	<b>16-26</b>
5-1 Adjustments Before Observation .....	16-24
5-2 Orthoscopic Observation .....	25
5-3 Conoscopic Observation .....	26
<b>6 SPECIFICATIONS</b>	<b>27-28</b>
<b>7 OPTICAL CHARACTERISTICS</b>	<b>29</b>
<b>8 TROUBLESHOOTING GUIDE</b>	<b>30</b>

# IMPORTANT

The BX51/52-P and BX41-P have different combinations of microscope frames and stages.

<b>Module</b>	BX51/52-P	BX41-P
<b>Microscope frame</b>	BX51TF/BX52TF	BX41TF
<b>Stage</b>	U-SRP	U-SRG2

## 1 Getting Ready

1. A microscope is a precision instrument. Handle it with care and avoid subjecting it to sudden or severe impact.
2. The BX51/52, BX41 series microscope can be used with up to two additional intermediate attachments (e.g., U-DO3 dual-viewing attachment, U-CA or U-ECA magnification changer, etc.). When using an additional intermediate attachment, please make sure with your Olympus representative or the latest brochure.
3. Do not use the microscope where it is subjected to direct sunlight, high temperature and humidity, dust or vibrations. Install it on stable, level bench. For operation environment conditions, see SPECIFICATIONS on page 28.

## 2 Caution

If the microscope is used in a manner not specified by this manual, the safety of the user may be imperiled. In addition, the equipment may also be damaged. Always use the equipment as outlined in this instruction manual.

The following symbols are used to set off text in this instruction manual.

- ▲ : Indicates that failure to follow the instructions in the warning could result in bodily harm to the user and/or damage to equipment (including objects in the vicinity of the equipment).
- ★ : Indicates that failure to follow the instructions could result in damage to equipment.
- ◎ : Indicates commentary (for ease of operation and maintenance).

# 1 NOMENCLATURE

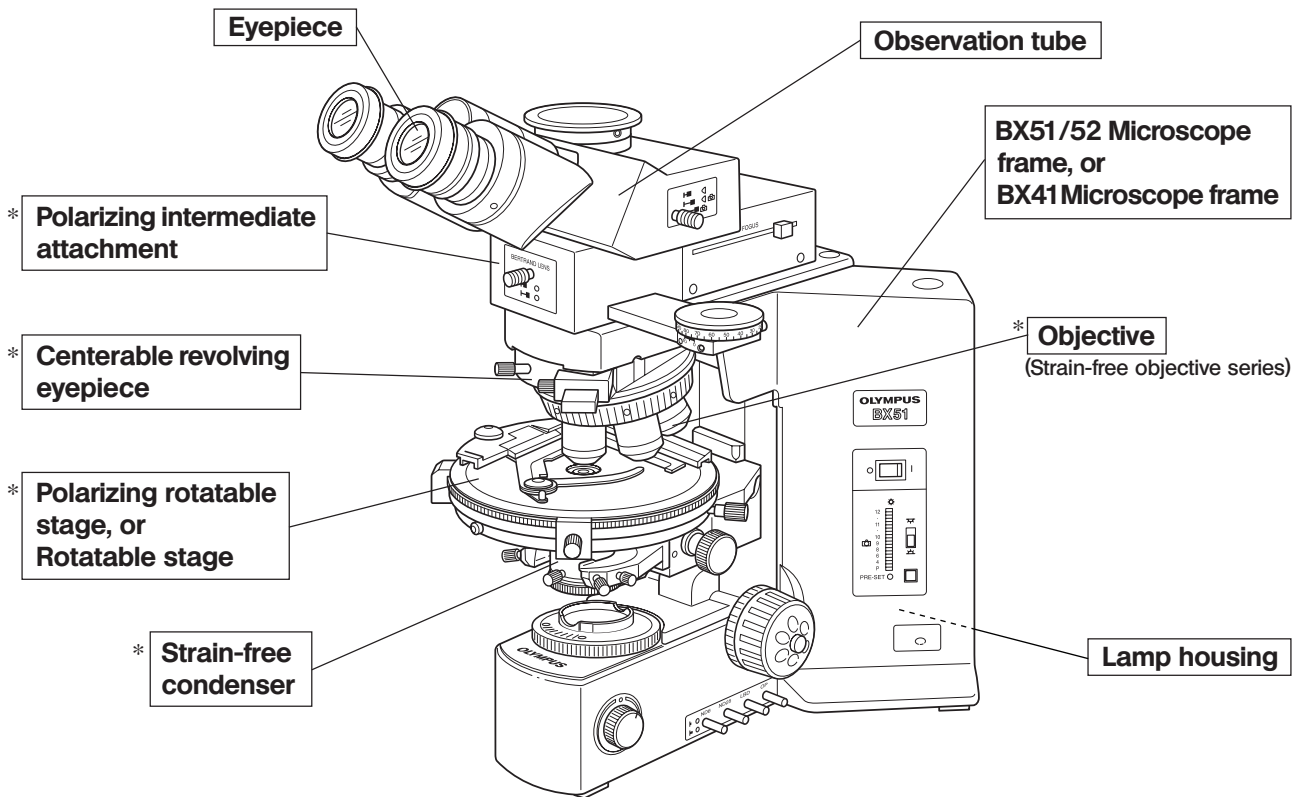

\*Components for polarized light observation

# 2 ASSEMBLY

## 2-1 Assembly Diagram

The diagram below shows how to assemble the various components. The numbers indicate the order of assembly.  
©For details on the BX51/52, BX41 microscope frame, consult the BX51/52, BX41 manual.

★ When assembling the components, make sure that all parts are free of dust and dirt, and avoid scratching any parts or touching glass surfaces.

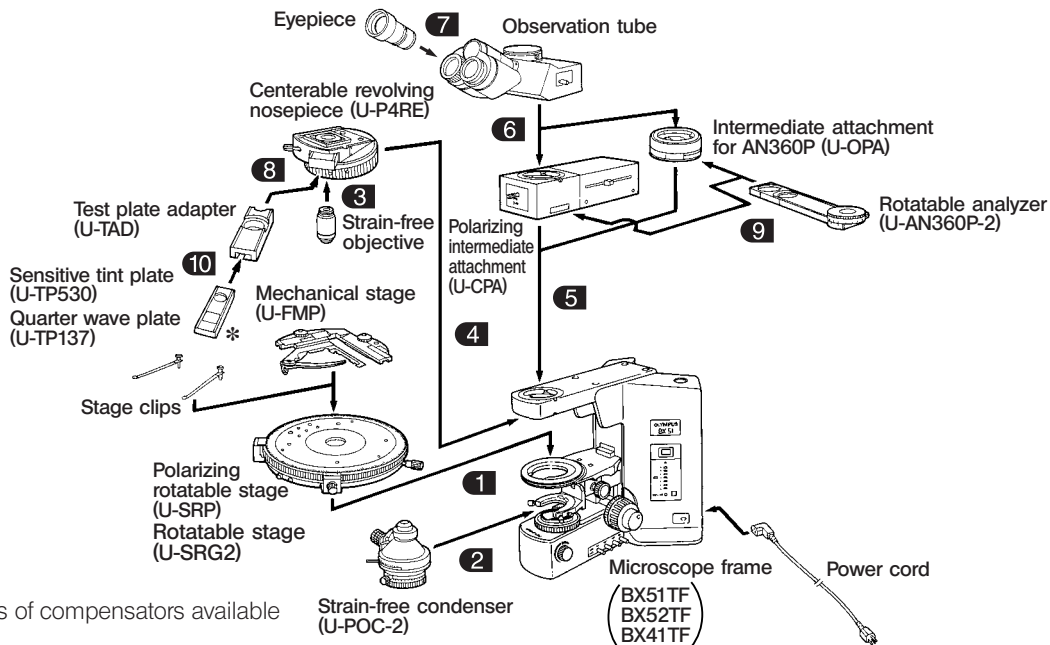

## 2-2 Detailed Assembly Procedure

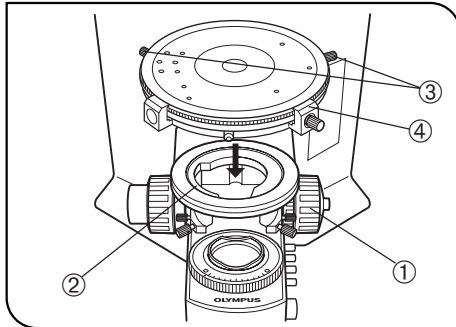

Fig. 1

### 1 Attaching the Stage (U-SRP) (Fig. 1)

1. Turn the coarse adjustment knob ① to lower the substage assembly ② to its lower limit.
2. Loosen the centering knobs ③.
3. Position the stage with the vernier scale ④ in front, and carefully lower the stage onto the round dovetail on the stage bracket ② with the positioning pin on the stage aligned with the groove on the front of the stage bracket, then loosely tighten the centering knobs.

#### When using the U-SRG2

- Using the Allen screwdriver provided with the microscope frame, loosen the clamping screw on the front of the stage. Then, after lowering the stage onto the stage bracket, tighten the clamping screw.

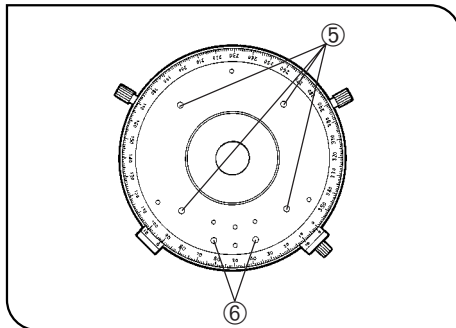

Fig. 2

#### Mounting Stage Clips and Mechanical Stage (U-FMP) (Fig. 2)

- Insert the stage clips securely into any two holes ⑤ on the stage top surface.
- Mount the mechanical stage so that the positioning pins on the underside fit into the positioning holes ⑥ on the stage top surface. Using the Allen screwdriver provided with the microscope frame, tighten the clamping screw.

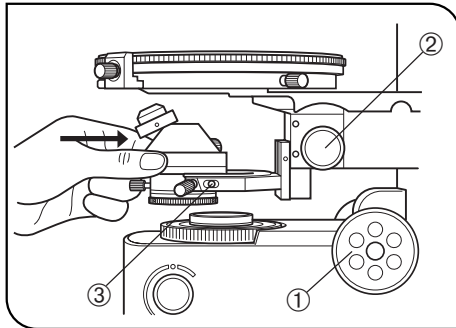

Fig. 3

## 2 Mounting the Condenser (U-POC-2)

(Fig. 3)

1. Turn the coarse adjustment knob ① to raise the stage to its upper limit.
2. Turn the condenser height adjustment knob ② to lower the condenser holder to its lower limit.
3. Loosen the condenser clamping screw ③.
4. Position the condenser with the scale markings in front, insert it into the substage fork as far as it will go. Align the positioning pin at the back of the condenser with the groove in the substage fork. Swing the top lens out of the way before inserting the condenser.
5. Tighten the condenser clamping screw, then raise the condenser to its upper limit.



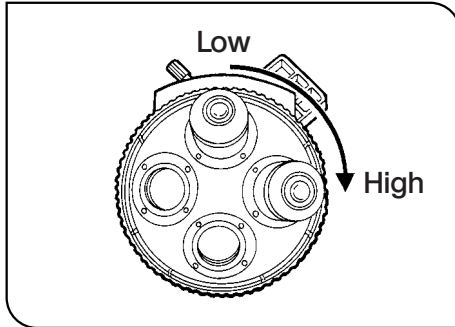

Fig. 4

### 3 Mounting the Objectives

(Fig. 4)

★ Insert the 10X or 20X objective into the primary hole (position where black rubber plugs are inserted into the centering holes on the nosepiece).

Mount the other objectives in such a manner, that the magnification increases from low to high power in a clock-wise direction from the primary hole.

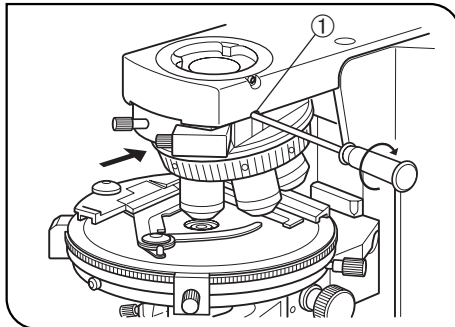

Fig. 5

### 4 Mounting the Revolving Nosepiece (U-P4RE)

(Fig. 5)

1. Turn the coarse adjustment knob to lower the stage all the way.
2. Using the Allen screwdriver, loosen the nosepiece clamping screw ① on the microscope frame.
3. Carefully slide the nosepiece along the dovetail to its limit, in the direction of the arrow.
4. Clamp the nosepiece by tightening the nosepiece clamping screw.

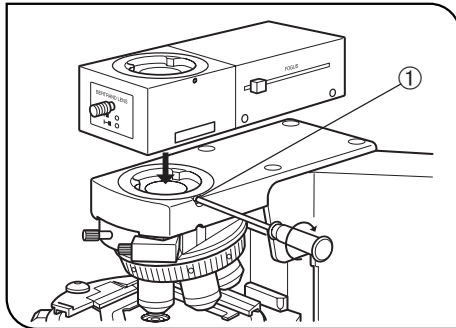

Fig. 6

## 5 Mounting the Intermediate Attachments

(Fig. 6)

1. Using the Allen screwdriver, loosen the observation tube clamping screw ① on the microscope frame.
2. Insert the circular dovetail mount at the bottom of the intermediate attachments into the opening on the microscope frame and clamp by tightening the clamping screw ①.

### When Using Polarizing Intermediate Attachment (U-CPA)

- ★ Always make sure to mount this unit in such a manner, that it is parallel to the arm.

### Intermediate Attachment for AN360P (U-OPA)

- ★ The position of this intermediate tube can be adjusted later. At this point, place the tube so the nameplate is toward the rear.

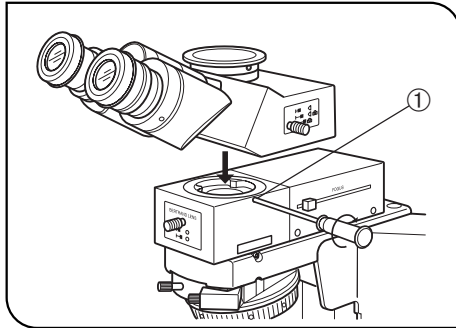

Fig. 7

**6 Mounting the Observation Tube (Fig. 7)**

1. Using the Allen screwdriver, fully loosen the observation tube clamping screw ① on the intermediate attachment.
2. Insert the circular dovetail mount at the bottom of the observation tube into the opening on the intermediate attachment, placing the observation tube to point the binocular eyepieces towards the front. Fasten the observation tube by tightening the clamping screw.

**7 Mounting the Eyepieces**

Insert the eyepiece with cross lines into the right hand eyepiece sleeve. Make sure the eyepiece is inserted so that the positioning pin on the eyepiece is inserted into the groove at the lower end of the sleeve.

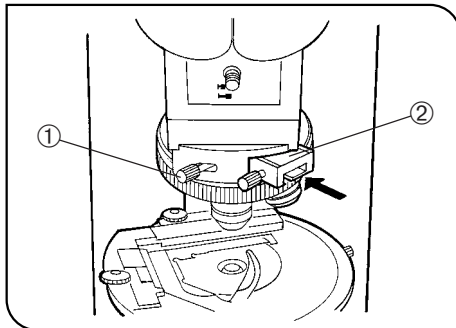

Fig. 8

**8 Mounting the Test Plate Adapter (U-TAD) (Fig. 8)**

1. Loosen the revolving nosepiece clamping knob ① and remove the dummy slider.
2. Insert the test plate adapter ② and securely tighten the clamping knob ①.

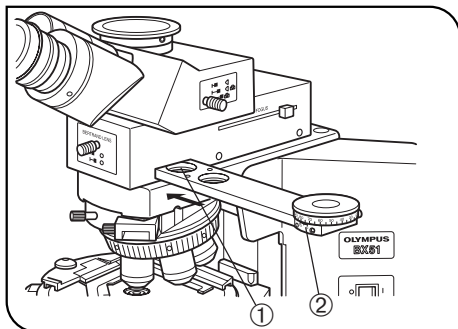

Fig. 9

## 9 Mounting Rotatable Analyzer (U-AN360P-2) (Fig. 9)

1. Place a desired ND filter (30 mm diam.) in the empty hole ① as required.
2. Insert the rotatable analyzer (U-AN360P-2) ② as far as the click-stop position. Then screw in the stopper knob ③. (Fig. 10)

When using the fixed analyzer U-ANT instead of the rotatable analyzer U-AN360P-2, place the fixed analyzer in the test plate adapter U-TAD. Position the fixed analyzer so that the positioning pin on the fixed analyzer fits into the groove. The fixed analyzer will be held in place by a magnet.

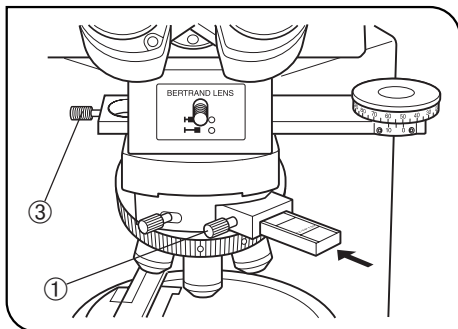

Fig. 10

## 10 Mounting Test Plate Compensator (Fig. 10)

1. Loosen the test plate adapter (U-TAD) clamping knob ①.
2. Insert the sensitive tint plate (U-TP530), quarter wave plate (U-TP137), or any of the other compensators (6 types) into the test plate adapter, and securely tighten the clamping knob.

# 3 CONTROLS

The illustration shows the U-CPA set. Other components are introduced on the following pages.

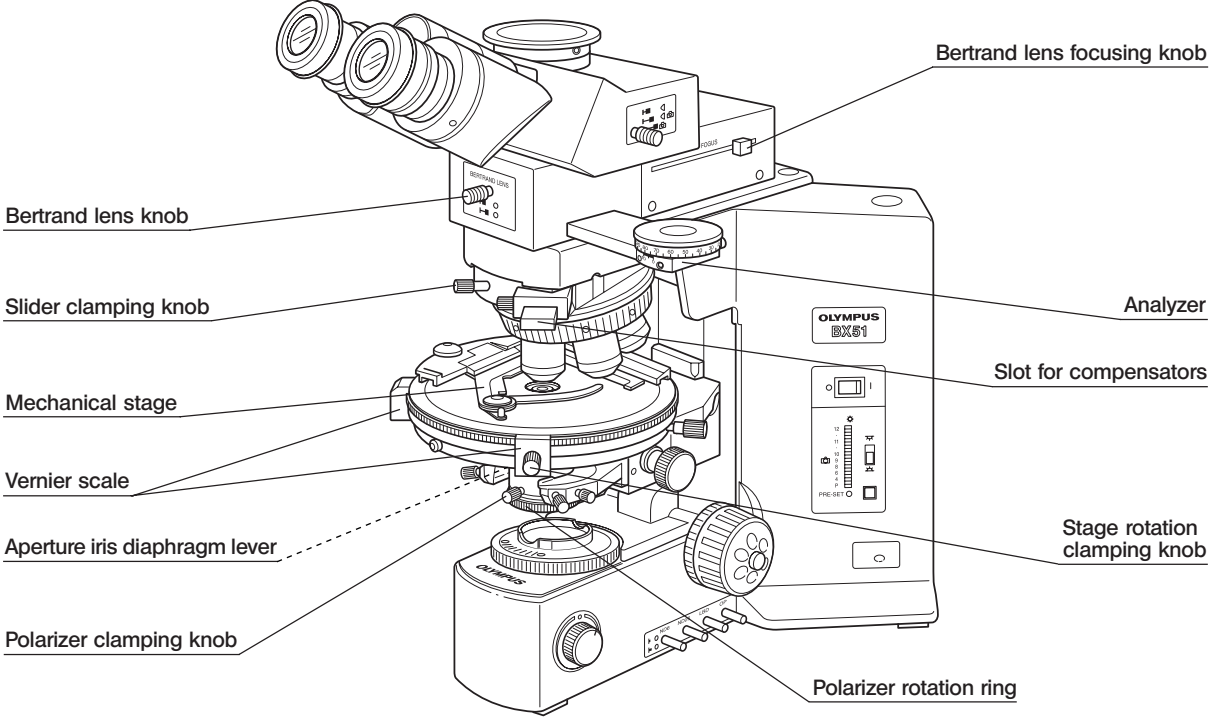

### Intermediate Adapter for AN360P (U-OPA)

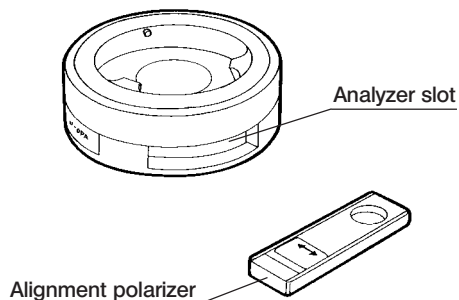

### Rotatable Analyzer (U-AN360P-2)

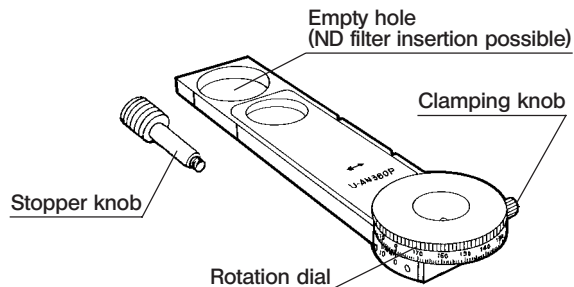

### Test Plate Adapter (U-TAD)

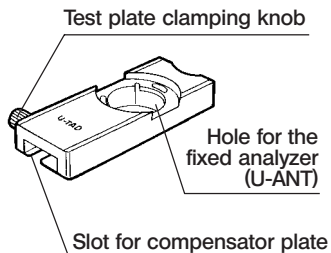

### Sensitive Tint Plate (U-TP530)

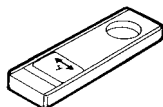

### Quarter Wave Plate (U-TP137)

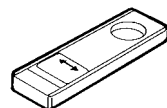

### Rotatable Stage (U-SRG2)

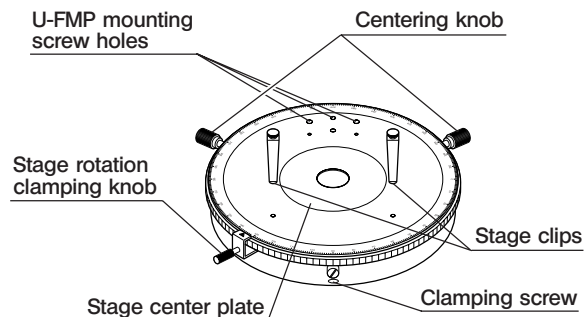

# 4 USING THE CONTROLS

## 4-1 Stage

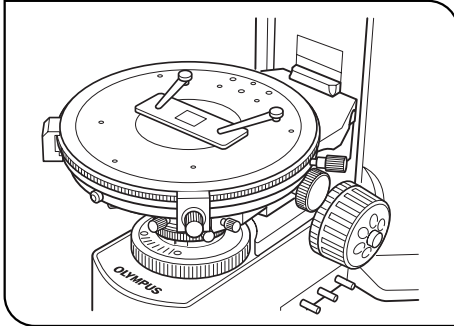

Fig. 11

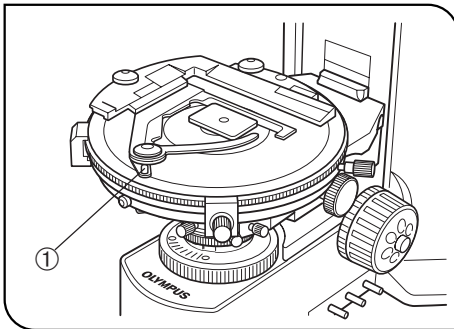

Fig. 12

### 1 Specimen Placement

#### When Using the Stage Clips

(Fig. 11)

Position the specimen in the center, and clamp the specimen with the stage clips.

#### When Using the Mechanical Stage (U-FMP)

(Fig. 12)

Open the spring-loaded finger ① and place the specimen on the stage.  
 ★ Applicable slide glass is for inorganic substances (28 x 48 mm) and organic substances (26 x 76 mm) with cover glass thickness of 0.17 mm.

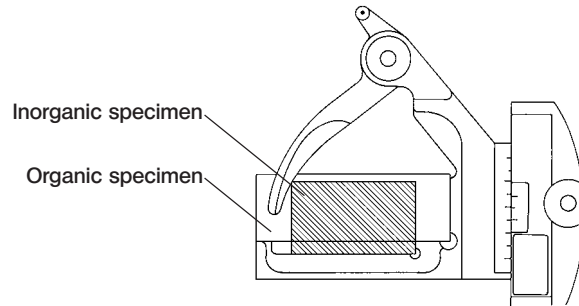

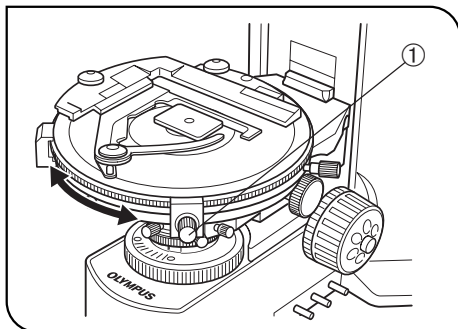

Fig. 13

## 2 Stage Rotation

(Fig. 13)

When the stage rotation clamping knob ① is loosened, the stage can be rotated horizontally through 360°.

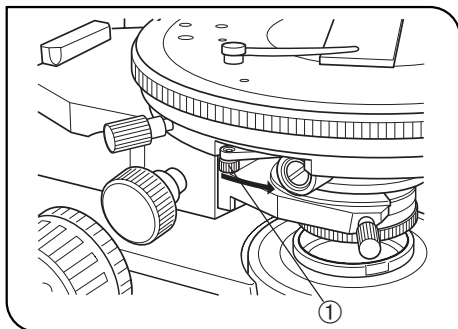

Fig. 14

## 3 Using 45° Click Stop Lever (U-SRP only)

(Fig. 14)

When the 45° click stop lever ①, located at the right side of the stage, is moved toward the observer, and the stage is moved from this position to the first click-stop position, the specimen is moved 45° to its diagonal position. To release the 45° click stop function, push back the lever.

★ When releasing the 45° click stop function by pushing back the lever, do so at a click-stop position.



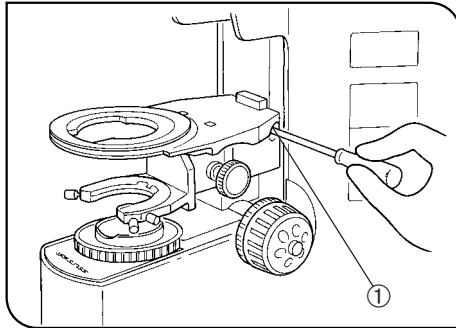

Fig. 15

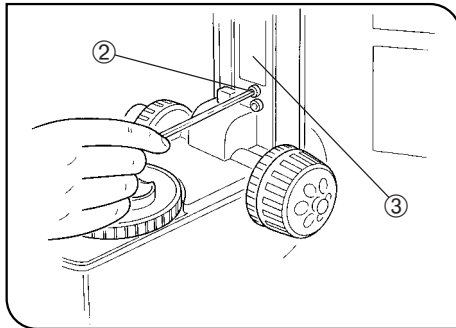

Fig. 16

#### 4 Stage Height Adjustment

(Figs. 15 & 16)

Ⓞ By lowering the position of the substage, the microscope will accommodate specimens with a maximum height of 35 mm. This is useful when observing metallurgical specimens and other thick objects.

1. Lower the stage to its lower limit, then remove the stage from the microscope. (See page 4.)
2. Using the Allen screwdriver, loosen the substage bracket clamping screw ① and remove the substage assembly. (Fig. 15)
3. Turn the coarse adjustment knob and raise the focusing block ③ to where the stopper screw ② in the arm becomes visible. (Fig. 16)
4. Using the Allen screwdriver, loosen and remove the upper stopper screw ②.
5. Reattach substage assembly and stage.

Ⓞ Store the remove stopper screw ② in a safe place so that it will not be lost, if needed again.

## 4-2 Intermediate Polarizing Attachment

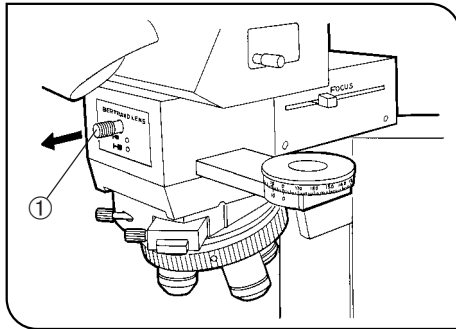

Fig. 17

### 1 Using the Bertrand Lens (U-CPA only)

(Fig. 17)

By manipulating the Bertrand lens knob ① on the front, the Bertrand lens is inserted into or removed from the light path. At the pushed-in (●) position, the lens is engaged. At the pulled-out (○) position, the lens is removed from the light path.

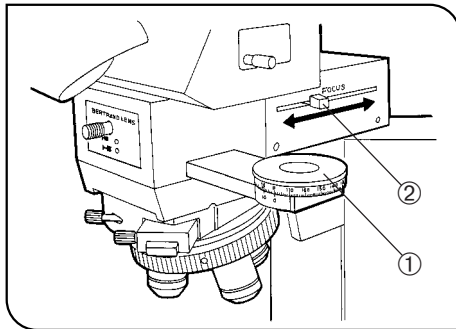

Fig. 18

### 2 Using the Analyzer

(Fig. 18)

The analyzer ① is engaged when pushed in to the second click-stop position. To disengage the analyzer, and to place the empty hole in the light path, pull the analyzer out to the first click-stop.

### 3 Focusing the Conoscopic Image (U-CPA only)

(Fig. 18)

To focus the conoscopic image, manipulate the Bertrand lens focusing knob ②. While observing the conoscopic image, move the knob to find the position where image is sharply focused.

# 5 POLARIZED LIGHT OBSERVATION

## 5-1 Adjustments Before Observation

In polarized light microscopy ultimate performance is not obtainable unless optical adjustments are made correctly. Always performed the following adjustments before observation. Remove the quarter wave plate and sensitive tint plate from the light path.

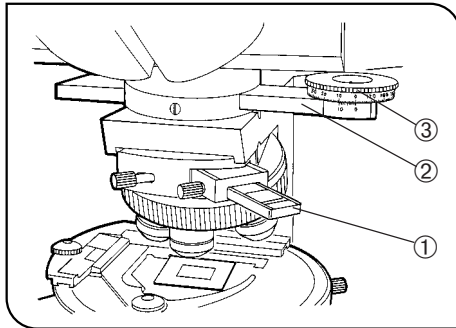

Fig. 19

### 1 Adjusting the Optical Axis

When Using the Intermediate Attachment for AN360P (U-OPA) (Figs. 19 & 20)

★ Make sure the 10X objective is inserted into the primary hole on the centerable revolving nosepiece.

1. Fully insert the alignment polarizer ①, provided with the U-OPA into the test plate adapter (U-TAD). Tighten its clamping knob. (Fig. 19)
2. Remove the condenser.
3. Insert the rotatable analyzer (U-AN360P-2) ② into the analyzer slot on the intermediate attachment. Engage the analyzer, loosen the clamping screw and set the analyzer's rotation dial ③ to 0°. (Fig. 19)

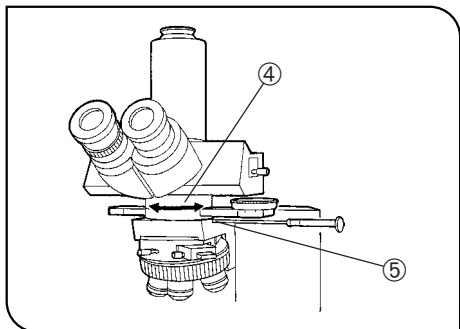

Fig. 20

4. Slightly loosen the intermediate adapter clamping screw ④. (Fig. 20)
5. While observing the field of view, rotate the intermediate attachment for AN360P (U-OPA) ④ until complete extinction is obtained. At this point, tighten the intermediate attachment clamping screw ⑤. (Fig. 20)
6. Remove the provided alignment polarizer.
7. Attach the condenser.
8. Center the condenser. (Refer to page 18 in the BX51/52 instruction manual or page 16 in the BX41 instruction manual.)

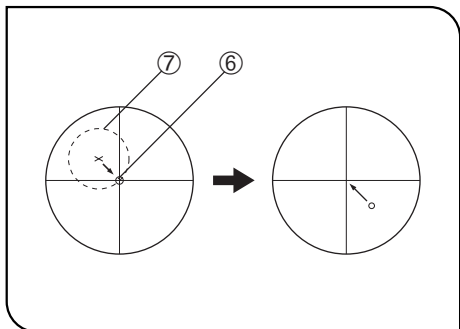

Fig. 21

9. Centering the rotatable stage (Figs. 21 & 22)
    - (1) Place the specimen.
    - (2) Focus on the specimen and look for an easily recognizable detail ⑥ in the field. Move this detail in the center of the eyepiece cross lines.
    - (3) When the stage is rotated, the detail moves in circle ⑦. Manipulate the two stage centering knobs ⑧ to coincide the imaginary center of the circle ⑦ circumscribed by the detail with the intersection of the eyepiece cross lines.
    - (4) Moving the specimen only, move a new specimen detail into the cross line center.
- Ⓞ Repeat steps (3) and (4) several times until the center of the stage rotation is in the center of the cross lines, i.e., when rotating the stage, the specimen stays in the center of the cross lines.

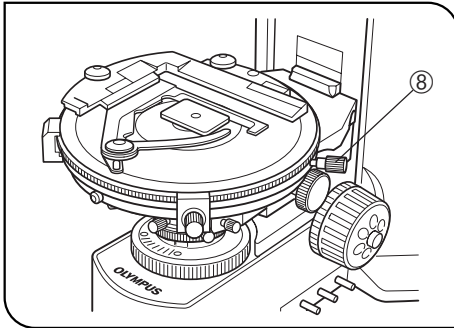

Fig. 22

(5) Clamp the stage with the stage rotation clamping knob.

10. This concludes centering of the optical axis for the 10X objective, which will act as the reference objective. Now, center the other objectives with the centerable nosepiece by engaging the objectives into the light path one after another.

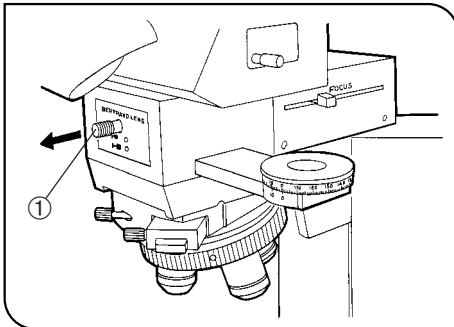

Fig. 23

**When Using Polarizing Intermediate Attachment (U-CPA)**

• Normal Observation

★ Make sure the 10X objective is inserted into the primary hole on the centerable revolving nosepiece.

1. Pull out the Bertrand lens knob ① to the OUT (○) position. (Fig. 23)
2. Center the condenser. (Refer to page 18 in the BX51/52 instruction manual or page 16 in the BX41 instruction manual.)
3. Follow steps 9 and 10 in “When Using the Intermediate Attachment for AN360”.

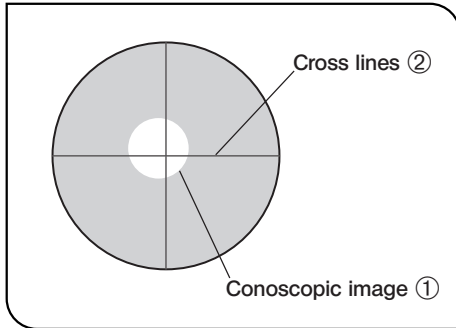

Fig. 24

Note: During conoscopic observation, the center of the conoscopic image ① and the intersection of the cross lines ② may not coincide. However, employment of the universal infinity optical design ensures that this disagreement will have no measurable effect during actual observation. However, if the disagreement is distracting, adjust in the same manner as when using the U-CPA (for photomicrography), described in the following paragraph.

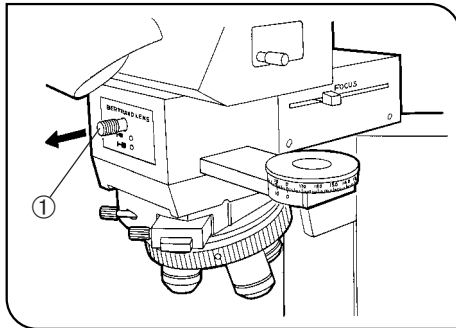

Fig. 25

**When Using Polarizing Intermediate Attachment (U-CPA)**

• **Photomicrography**

1. Using the tip of a mechanical pencil, etc., push out, in the direction of the objective hole, the black rubber plugs inserted into the centering holes of the primary hole where the 20X or 10X objective is inserted.
2. Pull out the Bertrand lens knob ① to the OUT (O) position. (Fig. 25)
3. Adjust the position of the intermediate tube (Refer to page 7)
4. Center the condenser. (Refer to page 18 in the BX51/52 instruction manual or page 16 in the BX41 instruction manual.)
5. Push in the Bertrand lens knob ① to the IN (●) position for conoscopic observation.

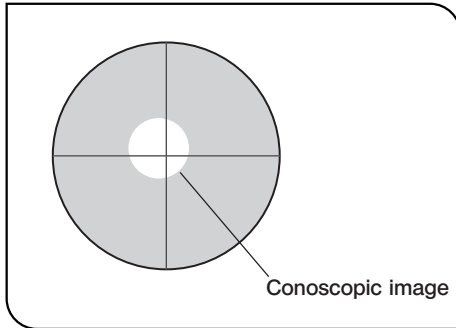

Fig. 26

6. To brighten and facilitate observation of the conoscopic image during optical axis adjustment, rotate the analyzer slightly away from the position of total extinction. (Fig. 26)

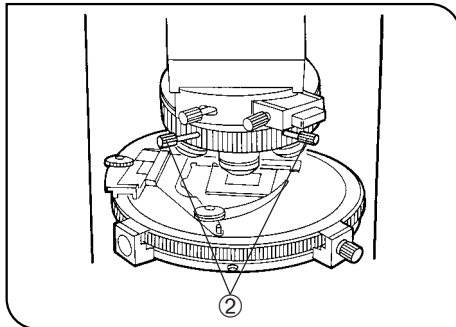

Fig. 27

7. Insert the two provided centering wrenches ② into the centering holes for the primary hole with the 20X or 10X objective on the nosepiece.
8. Manipulate the centering wrenches ② to bring the bright center portion of the conoscopic image into the center of the field of view (Fig. 27)
9. Pull out the Bertrand lens knob to the OUT (O) position. At this state, center the condenser again, as in step 4 above.

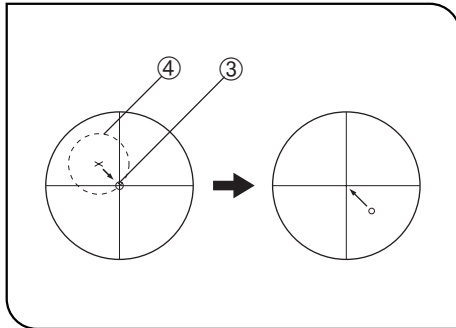

Fig. 28

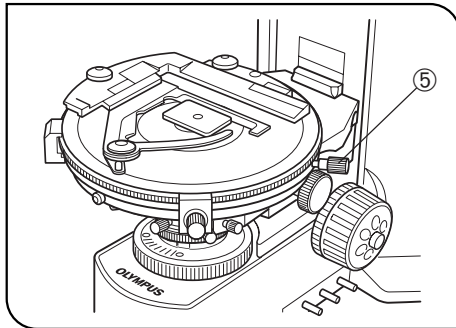

Fig. 29

#### 10. Centering the rotatable stage (Figs. 28 & 29)

- (1) Place the specimen.
- (2) Focus on the specimen and look for an easily recognizable detail ③ in the field. Move this detail in the center of the eyepiece cross lines.
- (3) When the stage is rotated, the detail moves in circle ④. Manipulate the two stage centering knobs ⑤ to coincide the imaginary center of the circle ④ circumscribed by the detail with the intersection of the eyepiece cross lines. Depending on the degree of the stage decentration, this will move the specimen detail in the opposite direction, away from the cross line center.

(4) Moving the specimen only, move a new specimen detail into the cross line center.

⊙ Repeat steps (3) and (4) several times until the center of the stage rotation is in the center of the cross lines, i.e., when rotating the stage, the specimen detail stays in the center of the cross lines.

(5) Clamp the stage with the stage rotation clamping knob.

11. This concludes centering of the optical axis for the 20X or 10X objective, which will act as the reference objective. Now, center the other objectives with the centerable nosepiece by engaging the objectives into the light path one after another.



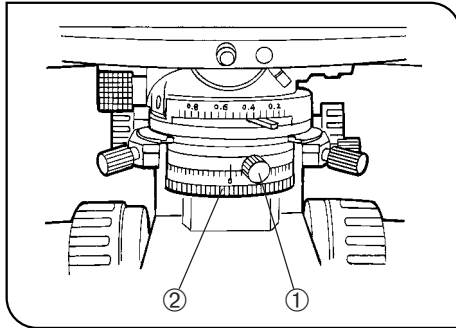

Fig. 30

## 2 Adjusting for Extinction

(Fig. 30)

★ Remove specimen, test plate, compensator, etc. from the light path.

1. Swing out the top lens of the condenser, and engage the 10X objective.
2. Insert the rotatable analyzer into the light path and set vibration direction scale at the 0° position. Clamp with the clamping knob. (Fig. 30)
3. Set the polarizer scale at the 0° position.
4. Loosen the polarizer clamping knob ①. Rotate the polarizer rotation dial ②, until complete extinction is obtained. At this point, tighten the clamping knob ①. (Fig. 30)

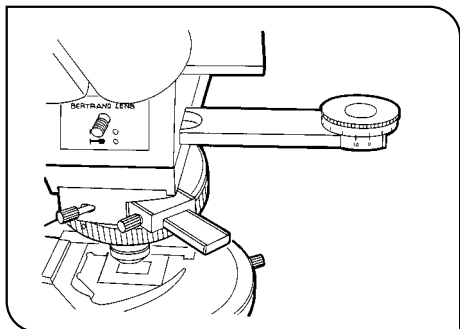
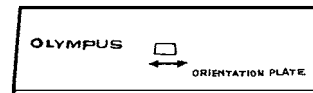

Fig. 31

### 3 Adjusting the Eyepiece Cross Lines

(Fig. 31)

© To align the eyepiece cross lines and the vibration direction, the orientation plate provided with the U-CPA or U-OPA is required.



Orientation plate (U-PJ: Single module name)

★ Remove the test plate adapter and the compensator from the light path.

1. Swing out the top lens of the condenser.
2. Place the orientation plate on the stage. Remove the analyzer from the light path, and use the 4X objective to focus.

3. Coincide the orientation plate's center portion with the intersection of the eyepiece cross lines. Engage the analyzer into the light path (in case of U-AN360P-2, set the analyzer to position 0°) to obtain crossed filters position (extinction).
4. While observing, rotate the stage to locate the position where the orientation plate is darkest. At this point, clamp the stage.
5. Remove the analyzer from the light path. Set to brightfield, and slightly loosen the observation tube clamping screw.
6. Rotate the observation tube to position the eyepiece cross line parallel to the fiducial line of the orientation plate. Tighten the observation tube clamping screw.

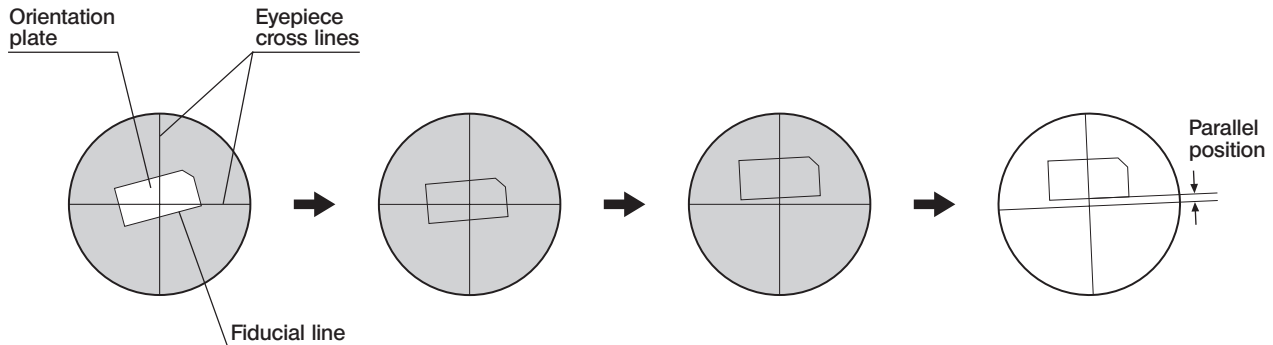

## 5-2 *Orthoscopic Observation*

©In principle, polarized light enters the light path, parallel to the optical axis, to enable observation of the optical characteristics of the specimen. Therefore, swing out the top lens of the condenser. Use 4X to 100X objectives.

1. When using the polarizing intermediate attachment U-CPA, pull out the Bertrand lens knob to remove the Bertrand lens from the light path.
2. Insert the analyzer and perform observation.

**★When the top lens is swung out, the aperture iris diaphragm and field iris diaphragm will not function normally.**

**★If the aperture iris diaphragm is stopped down, the field of view may be restricted.**

3. Insert a test plate (sensitive tint plate (U-TP530), quarter wave plate (U-TP137)) into the test plate slot. When fully inserted, the plate is engaged. To remove the test plate from the light path, pull out to first click-stop position. For details on other compensators, see the separate instruction manuals.

### 5-3 Conoscopic Observation

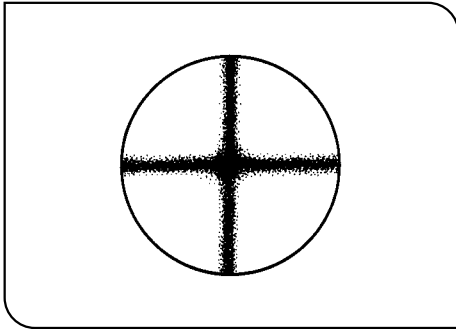

Fig. 32

- ◎ Use 20X to 100X objectives.
- 1. Engage the analyzer and adjust for extinction position.
- 2. Swing the condenser top lens into the light path.
- 3. When using the polarizing intermediate attachment U-CPA, push in the Bertrand lens knob to engage the Bertrand lens into the light path.
- 4. Engage an objective of your choice (20X to 100X).
- 5. Open the aperture iris diaphragm.
- 6. Slide the focusing knob on the U-CPA to focus on the conoscopic image.
- ◎ When the polarizing intermediate attachment U-CPA is not used, conoscopic observation is possible by removing an eyepiece from the observation tube and looking at the rear focal plane of the objective directly.
- ◎ To obtain good image contrast, place an interference filter (45IF546) in the filter holder on the light exit of the microscope.
- ◎ If the periphery of the conoscopic image is dark, move the condenser vertically to find the position where the periphery is brightest.

# 6 SPECIFICATIONS

Item	Specifications		
	Polarizing intermediate attachment (U-CPA)		Intermediate attachment for AN360P (U-OPA)
1. Polarizing intermediate attachment (U-CPA and U-OPA)	Field No.	22	
	Bertrand lens	Focusable	—
	Bertrand aperture stop	Fixed diaphragm	—
	Bertrand lens knob position for switch between orthoscopic and conoscopic observation	Pushed in position: ● IN Pulled out position: ○ OUT	—
	Analyzer slot	Slot for rotatable analyzer (U-AN360P-2)	
2. Analyzer (U-AN360P-2)	360° dial rotation Minimum scale reading: 0.1° (Vernier scale)		
3. Revolving nosepiece (U-P4RE)	Type: Centerable quadruple Attachable compensators: Quarter wave plate (U-TP137), sensitive tint plate (U-TP530) and all kinds of compensators by means of test plate adapter (U-TAD).		
4. Stage (U-SRP)	Type: Polarizing rotatable stage with 3-point centering mechanism 360° horizontal rotation, clamps at any desired position 360° scale (minimum division: 1°; minimum reading 6' by means of vernier scale) 45° click stop knob <ul style="list-style-type: none"> <li>• Stage clips (U-SCB2) attachable for holding specimen in place</li> <li>• Attachable mechanical stage (U-FMP)</li> <li>• Universal stage (ZEISS Co. manufacture) attachable</li> </ul>		

Item	Specifications	
	Polarizing intermediate attachment (U-CPA)	Intermediate attachment for AN360P (U-OPA)
<b>5. Stage (U-SRG2)</b>	Type: Rotatable stage with 3-point centering mechanism 360° horizontal rotation, clamps at any desired position 360° scale (minimum division: 1° reading) <ul style="list-style-type: none"> <li>• Stage clips (U-SCB2) attachable for holding specimen in place</li> <li>• Attachable mechanical stage (U-FMP)</li> </ul>	
<b>6. Condenser (U-POC-2)</b>	Aplanatic/achromatic condenser, top lens swing-out type Polarizer 360° rotatable 0° position adjustable N.A. 0.9 (top lens swung in) Applicable objectives: 2X to 100X (2X to 4X objectives are used with the top lens swung out)	
<b>Operating environment</b>	<ul style="list-style-type: none"> <li>• Indoor use</li> <li>• Altitude up to 2000 m</li> <li>• Temperature: 5° to 40°C (41° to 104°F)</li> <li>• Maximum relative humidity 80% for temperatures up to 31°C (88°F) decreasing linearly to 50% relative humidity at 40°C (104°F)</li> <li>• Main supply voltage fluctuations not to exceed ±10% of the nominal voltage</li> <li>• Installation/Overtoltage Category II (In accordance with IEC60664)</li> <li>• Pollution Degree 2 (In accordance with IEC60664)</li> </ul>	

# 7 OPTICAL CHARACTERISTICS

– UIS series objectives not listed here can also be combined with this microscope. –

The table below shows the optical characteristics of different eyepiece and objective combinations. Objective specifications are marked on the objective (as shown in the diagram on the right).

**NOTE**

Refer to the latest catalogue or consult your local Olympus representative for the updated information on the eyepieces and objectives that can be combined with this microscope.

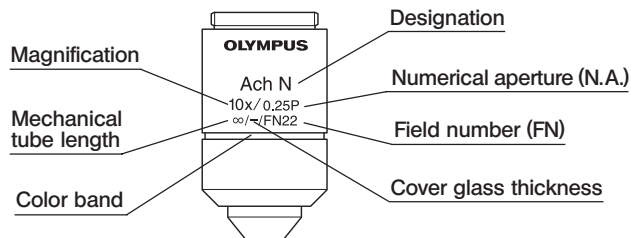

Optical character UIS2 objective	Magnification	N.A.	W.D. (mm)	Cover glass thickness (mm)	Resolution (μm)	Eyepiece WHN10X (FN22)			Remark
						Total mag.	Depth of focus (μm)	Field of view	
PlanN-P Plan Achromat for polarized light (FN22)	4X	0.10	18.5	–	3.36	40X	180.0	5.5	
AchN-P Achromat for polarized light (FN22)	10X	0.25	6.0	–	1.34	100X	28.0	2.2	Oil immersion
	20X	0.40	3.0	0.17	0.84	200X	6.09	1.1	
	40X	0.65	0.45	0.17	0.52	400X	3.04	0.55	
	100XO	1.25	0.13	0.17	0.27	1000X	0.69	0.22	



Under certain conditions, performance of this unit may be adversely affected by factors other than defects. If problems occur, please review the following list and take remedial action as needed. If you cannot solve the problem after checking the entire list, please contact your local Olympus representative for assistance.

Trouble	Cause	Remedy
<b>1. Optical System</b>		
a. Bulb is lit, but field of view remains dark.	Bertrand lens is engaged.	Remove the Bertrand lens from the light path.
	In the extinction condition.	Remove the analyzer from the light path.
b. Vignetting or uneven field of view.	Test plate is stopped at an intermediate position.	Set at click-stop position.
	During orthoscopic observation, the condenser top lens is placed in the light path or stopped at intermediate position.	Remove top lens completely from the light path.
c. The conoscopic image is not visible.	Condenser top lens is not placed in the light path.	Swing in the top lens.
	Bertrand lens is not placed in the light path.	Place Bertrand lens in the light path.
	Intermediate attachment for AN360P (U-OPA) is attached.	Replace it with the U-CPA if you have one. If you don't, look into the eyepiece sleeve to observe the conoscopic image.
d. Extinction is not obtainable.	The analyzer is not in the light path.	Engage the analyzer.

# *MEMO*



# **OLYMPUS®**

## **OLYMPUS CORPORATION**

2-43-2, Hatagaya, Shibuya-ku, Tokyo, Japan

## **OLYMPUS EUROPA GMBH**

Postfach 10 49 08, 20034, Hamburg, Germany

## **OLYMPUS AMERICA INC.**

2 Corporate Center Drive, Melville, NY 11747-3157, U.S.A.

## **OLYMPUS INDUSTRIAL AMERICA, INC.**

One Corporate Drive, Orangeburg, NY 10962, U.S.A.

## **OLYMPUS SINGAPORE PTE LTD.**

491B River Valley Road, #12-01/04 Valley Point Office Tower, Singapore 248373

## **OLYMPUS UK LTD.**

2-8 Honduras Street, London EC1Y 0TX, United Kingdom.

## **OLYMPUS AUSTRALIA PTY. LTD.**

31 Gilby Road, Mt. Waverley, VIC 3149, Melbourne, Australia.

## **OLYMPUS LATIN AMERICA, INC.**

6100 Blue Lagoon Drive, Suite 390 Miami, FL 33126-2087, U.S.A.

